



# SMART-VS

## SMART VISION SENSOR



- Machine Learning Assisted Setting
- No vision Tools programming required
- No need of skilled installers and Users
- Fast and Easy Setting like standard photosensor
- Up to three classification algorithm (PLUS version)
- Deterministic response time
- Fast Response time down to less than 20 ms (PLUS Version)
- 20 Images handling for comprehensive application set up (PLUS Version)

- Machine assisted trigger for sensor set up (PLUS Version)
- Electronic focus control
- 50...400 mm operating distance (PLUS version)
- 50...150 mm operating distance
- Bright and visible Red LED pointer
- Powerful white polarized light illuminator
- Green/Red LED Spot for GOOD/NO GOOD part
- Ethernet point to point communication available
- Easy and Intuitive WEB Server GUI for maintenance and job setting



### CODE DESCRIPTION

**SMART-VS - MR - 5 - 150 - WH - 0**

series	<b>SMART-VS</b>	Smart-Vision Sensor
type	<b>MR</b>	Metal housind radial optic STANDARD version
	<b>PL</b>	Metal housind radial optic PLUS version
connection	<b>5</b>	M12 connectors Power I/O + Ethernet
operating distance	<b>150</b>	Maximum operating distance
illuminator type	<b>WH</b>	Polarized White
output type	<b>0</b>	3 digital output

### AVAILABLE MODELS

description	images number	optic	illuminator	I/O	model
SVS WP 150MM OUT	6 (total)	7 mm	white polarized	3 Out + 2 In + ETH	<b>SMART-VS-MR-5-150-WH-0</b> (959971320)
SVS PLUS DIG OUT	20 (total)				<b>SMART-VS-PL-5-150-WH-0</b> (959970005)

## TECHNICAL FEATURES

	SMART-VS-MR-5-150-WH-0	SMART-VS-PL-5-150-WH-0
Power	10 to 30 Vdc	
Supply Voltage (Vdc) Consumption (A) Max.	0.40 - 0.14 A (4.2 W)	
Communication Interface Ethernet <sup>1</sup>	10/100 Mbit/s	
Inputs	Opto-coupled and polarity insensitive	
Max. Voltage	30 Vdc	
Max. Input Current	10 mA	
Output Type	Push-pull, NPN or PNP, short circuit protected	
Outputs	3 Outputs (DATA VALID, GOOD, NO GOOD)	3 combined digital outputs (DATA VALID, CLASS1, CLASS2, CLASS3)
VOUT (ILOAD = 0 mA) Max.	30 Vdc	
VOUT (ILOAD = 100 mA) Max.	3 Vdc	
ILOAD Max.	100 mA	
Operating distance	50...150 mm	50...400 mm
View angle	19°	
FOV area @ 50 mm	22 mm (H) x 16 mm (V)	
FOV area @ 150 mm	55 mm (H) x 41 mm (V)	-
FOV area @ 400 mm	-	137 mm (H) x 105 mm (V)
Response Time	Deterministic 50 ms	Deterministic but depending on application set-up minimum time is 20 ms
Max. Image to handle (GOOD+NO GOOD)	6 images	20 images
Max pcs per second	20 pcs per second	Depending on application set-up
Active Area Resolution	320 x 240 pixels	
Illuminator	White LED polarized	
Product Dimensions	H x W x L	
Connector at 0°	78 x 47 x 38 mm (3.1 x 1.9 x 1.5 in)	
Connector at 90°	58 x 47 x 58 mm (2.3 x 1.9 x 2.3 in)	
Weight	173 g (6.1 oz)	
Material	Aluminum with plastic PMMA protective window	
Operating Temperature <sup>2</sup>	0° to 50 °C (14 to 122 °F)	
Storage Temperature	-20 to 70 °C (-4 to 148 °F)	
Max. Humidity	90% non-condensing	
Vibration Resistance	14 mm @ 2 to 10 Hz; 1.5 mm @ 13 to 55 Hz; 2 g @ 70 to 500 Hz; 2 hours on each axis	
Shock Resistance	30 g; 11 ms; 3 shocks on each axis	
Protection Class 3	IP65 and IP67	

<sup>1</sup> The embedded Ethernet interface is intended for configuration only through connection to the device IP. Point-to-Point connection is recommended.

<sup>2</sup> High ambient temperature applications should use metal mounting bracket for heat dissipation.

<sup>3</sup> When correctly connected (fully tightened) to IP67 cables with seals.

# RESPONSE DIAGRAMS

SMART-VS-MR-5-150-\*\*-0

SMART-VS-PL-5-150-\*\*-0

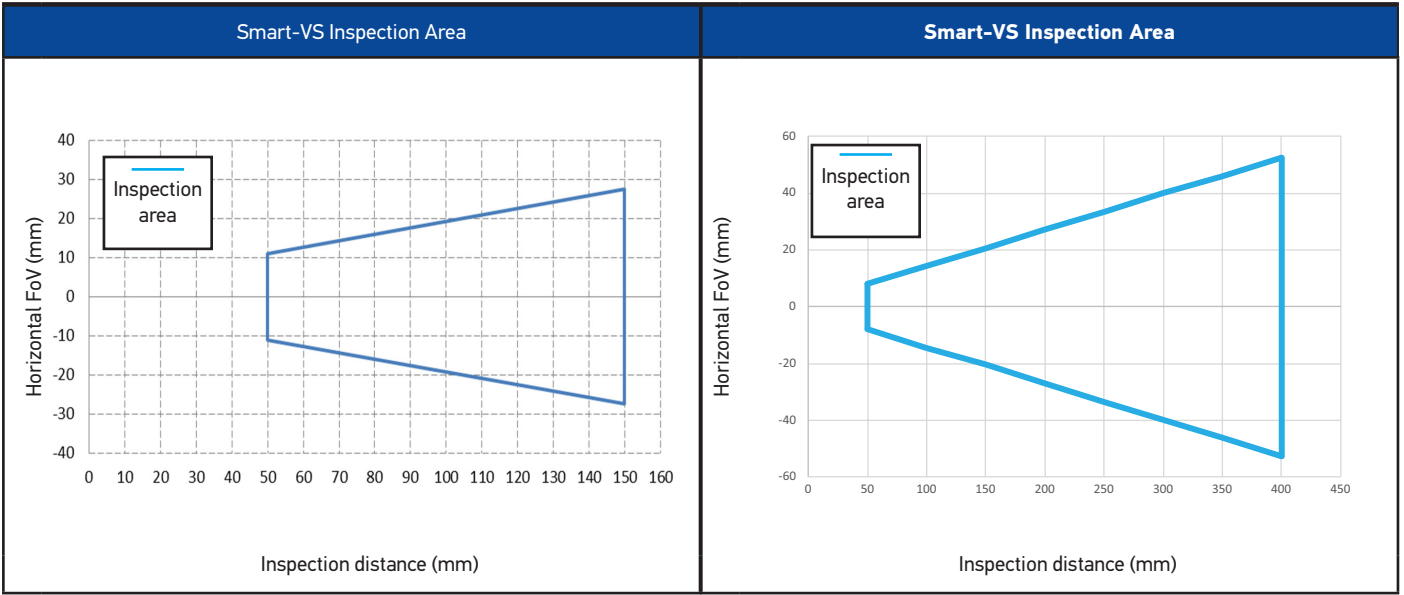

# DIMENSIONS

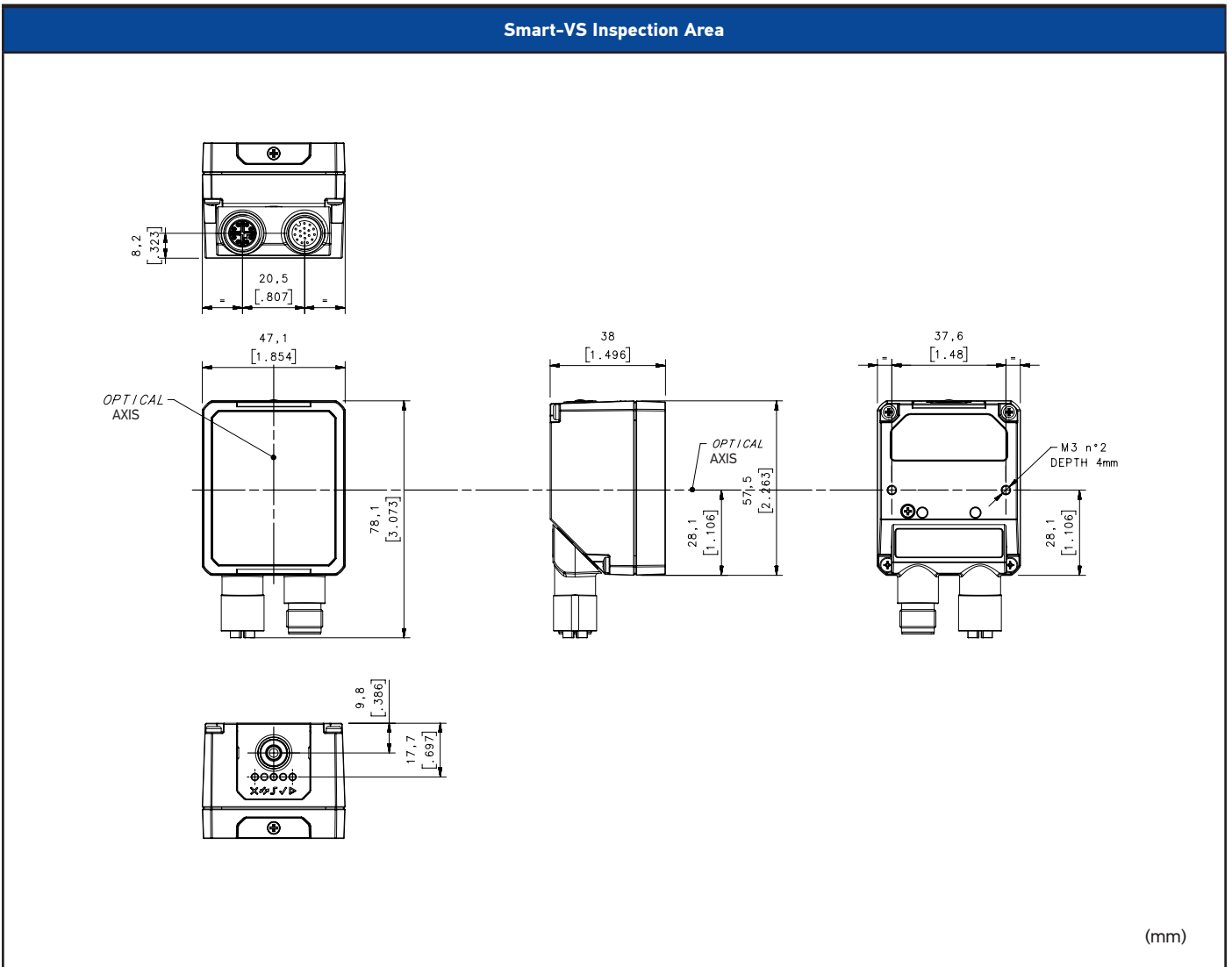

# SMART-**VS** CONNECTIONS

SMART  
SENSORS

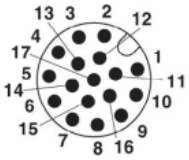

M12 17-pin Power and I/O Connector Pinout*			
Pin	Name	Color	Function
1	Vdc	Brown	Power supply input voltage +
2	GND	Blue	Power supply input voltage -
Connector case	Chassis		Connector case provides electrical connection to chassis
6	I1A	Yellow	I1A Trigger Input A (polarity insensitive)
5	I1B	Pink	I1B Trigger Input B (polarity insensitive)
13	I2A	Green	I2A Remote Teach A (polarity insensitive)
3	I2B	White	I2B Remote Teach B (polarity insensitive)
9	O1	Red	Data Valid PP
8	O2	Gray	GOOD Output PP
16	O3	Black	NO GOOD Output PP

\* The wire colors are referred to cables P/N 95A900052 and 95A900053

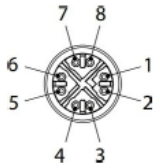

M12 8-pin Standard Ethernet Network Connector Pinout		
Pin	Name	Function
1	TX+	Transmit data (positive pin)
2	TX-	Transmit data (negative pin)
3	RX+	Receive data (positive pin)
4	RX-	Receive data (negative pin)
5	nc	Not Connected
6	nc	Not Connected
7	nc	Not Connected
8	nc	Not Connected

## INDICATORS AND SETTINGS

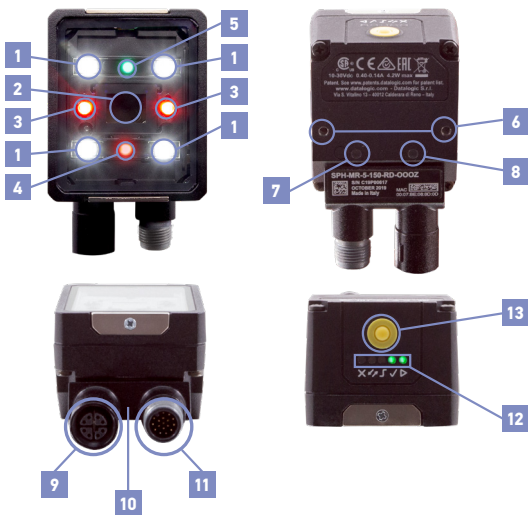

ITEM N.	DESCRIPTION
1	Illuminator with 4 powerful White LEDs with polaroid filter
2	7mm lens with automatic focus system
3	Aiming system with 2 powerful Red LEDs
4	Red Spot illuminator LED for NO GOOD detection object
5	Green Spot illuminator for GOOD detection object
6	2 holes for direct mounting or bracket
7	Blue Power Supply LED
8	Yellow Ethernet connection LED
9	M12 Ethernet X-coded female connector
10	Rotating connector block
11	M12-17 Pin Power Supply and I/O male connector
12	5 bright LED for User Interface signalization
13	Yellow TEACH-IN button for sensor set-up

### HMI CONFIGURATION



#### NO GOOD object

- blinking: NO GOOD object teaching
- in Run phase: NO GOOD object detected



#### For future use



#### Trigger

- trigger received



#### GOOD object

- blinking: GOOD object teaching
- in Run phase: GOOD object detected



#### Run

- device in RUN phase

# FIELD OF VIEW Calculation

Use the data in the following table to calculate the FOV for your application, referring to the draw and the formula below.

$D_0$	View angle horizontal	View angle vertical	View angle diagonal	Min Reading Distance mm
11 mm	19°	14,5°	24°	50 mm

The viewing angle has a tolerance of  $\pm 1^\circ$  depending on the reading distance.

$$FOV_x = 2 [ (d + d_0) * \tan (\alpha/2) ]$$

where:

**FOV<sub>x</sub>** = horizontal, vertical or diagonal FOV

**$\alpha$**  = horizontal, vertical or diagonal viewing angles.

**d** = reading distance (in mm) from window surface to code surface

**$d_0$**  = offset (in mm) from center of lens to external window surface

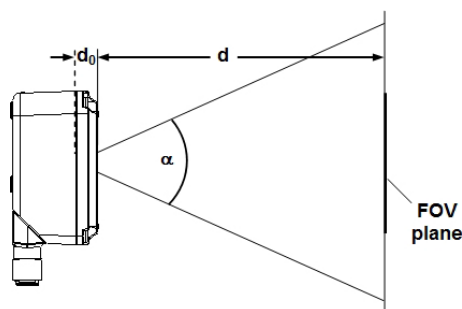

Example:

The FOV at a reading distance of 100 mm is:

$$FOV_H = 2[(100 \text{ mm} + 11 \text{ mm}) * \tan(19^\circ/2)] \approx 37 \text{ mm}$$

$$FOV_V = 2[(100 \text{ mm} + 11 \text{ mm}) * \tan(14,5^\circ/2)] \approx 28 \text{ mm}$$

## OPERATING PRINCIPLES AND APPLICATIONS

### Smart-VS simply clever

The Smart-VS is a Smart vision sensor simple and clever. It is simple outside since it can be handled and used like a standard photoelectric sensor but powerful and smart inside with a multiprocessor platform supporting and embedding the Artificial Intelligence technology. Its customized machine learning algorithms are empowering the detection system core enabling very complex and accurate object classification ensuring at same time a very simple setting procedure by the user. The user does not have to take care about programming or setting threshold of different vision tools, all these complex functionalities are

operated by the Smart-VS "brain".

The detection function will be accomplished with three easy and fast steps. The quick step is the GOOD condition teaching the second step is no good condition teaching the third will turn the sensor in learning and normal run status ready to detect GOOD or NO GOOD objects. The user will just present the objects in front of sensor eye and push the button to change acquisition steps until the sensor will start to think and act.











The sensor is especially suited for all the applications where it is needed to solve detection between two well specified object condition classes, like presence or absence of a specific feature or object orientation respect two sides, teaching the sensor with GOOD and NO GOOD condition.

The Smart-VS principle of working is to teach the sensor with GOOD and NO GOOD object condition, this is the basic rule for any application.

This is the reason why it can be used in an effective and reliable way for the presence/absence of object features for side orientation of objects referring to proper object attributes.

This working principle makes the sensor setting easy and independent by the type, material, color of the object that needs to be detected.



Application name	Solved cases (OK / NOT OK)
Check label presence	 
Cap orientation	 
Cap presence	 
Check printing on label	 

The main application targeted for the best use of the Smart-VS is mainly related to print and apply application where it is needed to detect presence or absence of Labels or text printing.

Liquid filler machineries where it is needed to detect the presence/absence of any kind of cap on any kind of bottles, vials, flasks of any material, does not matter if made of glass, plastic or with bright dark color shiny surfaces and different dimensions. Just make the sensor teach and learn the GOOD/NO GOOD condition and it will work. You do not need to set vision tools, sensitivity thresholds, image exposition, focus, sensor positioning or sensor sensitivity.

Bottling machines where it is needed to check if the label is present or not on the object making the sensor learning the presence/absence and then make it work immediately without additional settings, just pressing a push button or building up different receipts for different formats with an effective and easy WEB GUI interface.

**Application name**

Check label presence	
Cap orientation	
Cap presence	
Check printing on label	

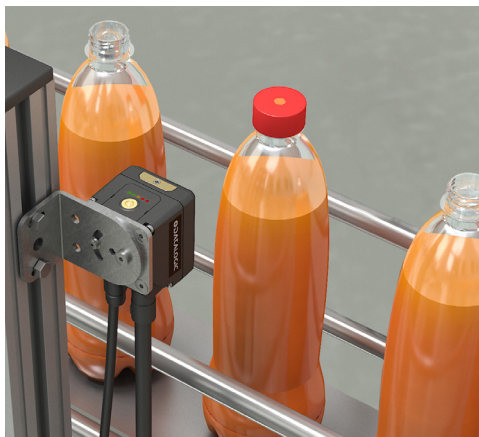

**A great value for all the applications**

The Smart-VS redefines the standard detection eliminating all the concerns regarding the use of standard sensors about unstable detection or complex installation layouts to perform the presence/absence or orientation applications, a Smart-VS based system will ensure:

- more stability in terms of different object materials and shape
- excellent stability on glass and metal parts
- more simple system installation
- more flexibility and adaptability about different production format
- easy setting avoiding more expensive and complex devices
- lower cost of ownership and maintenance

**SMART-VS SETTING METHODS**

**Easy and Comprehensive system integration**

The Smart-VS is very easy and simple to integrate in any application, it can be implemented like a sensor product, but it is much simpler than a smart camera or an ordinary smart sensor.

It is needed to provide a trigger signal by machine electrical phase or an external simple sensor or an encoder. The PC or Ethernet based terminal is an option needed to change configuration of the sensor (once a time) or for more complex set-up where it is needed to change and/or add job setting through the web interface with a browser, in most cases the need to have this connection is not necessary. The web interface can be a useful tool in case of trouble shooting

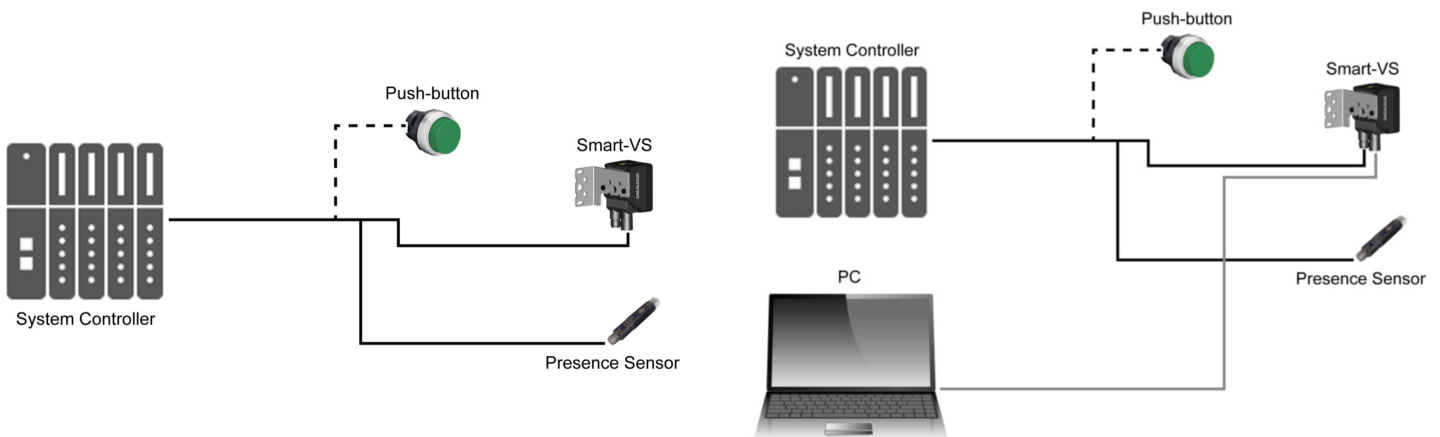

# WEB INTERFACE

## SMART-VS-MR-5-150-\*\*-0

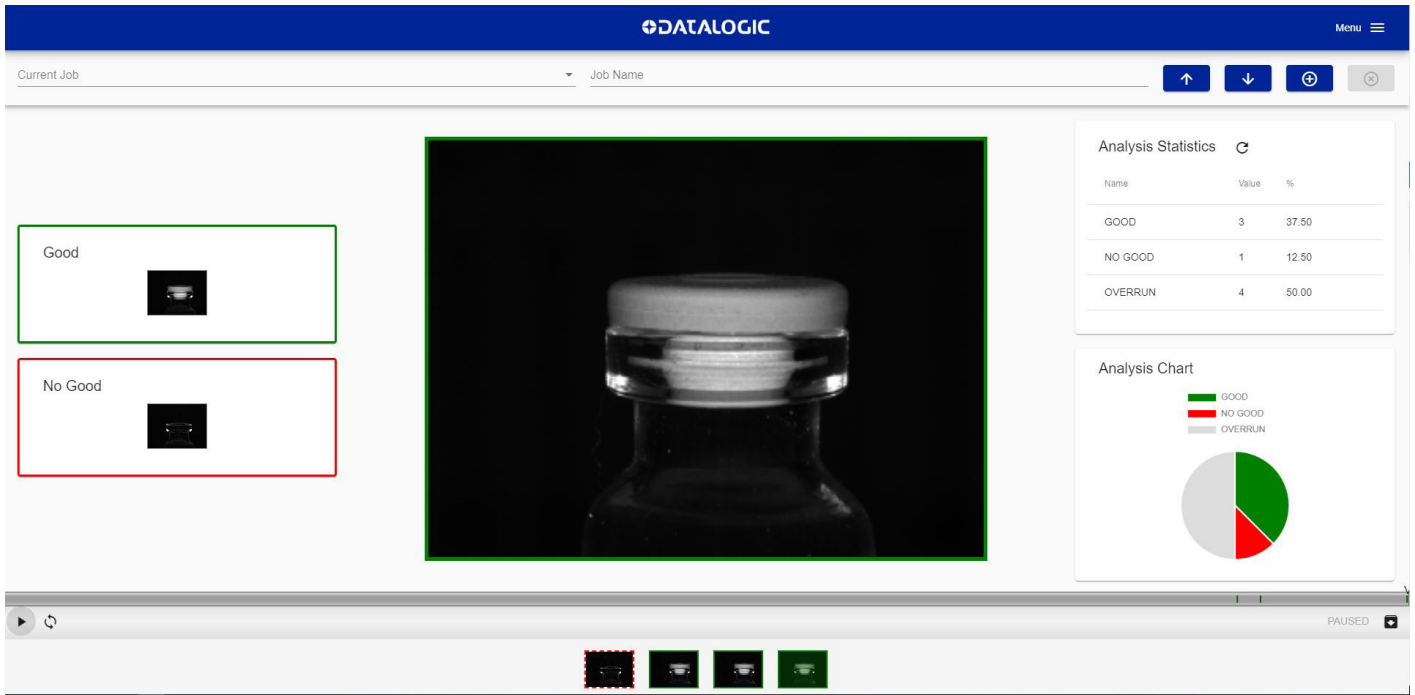

## SMART-VS-PL-5-150-\*\*-0

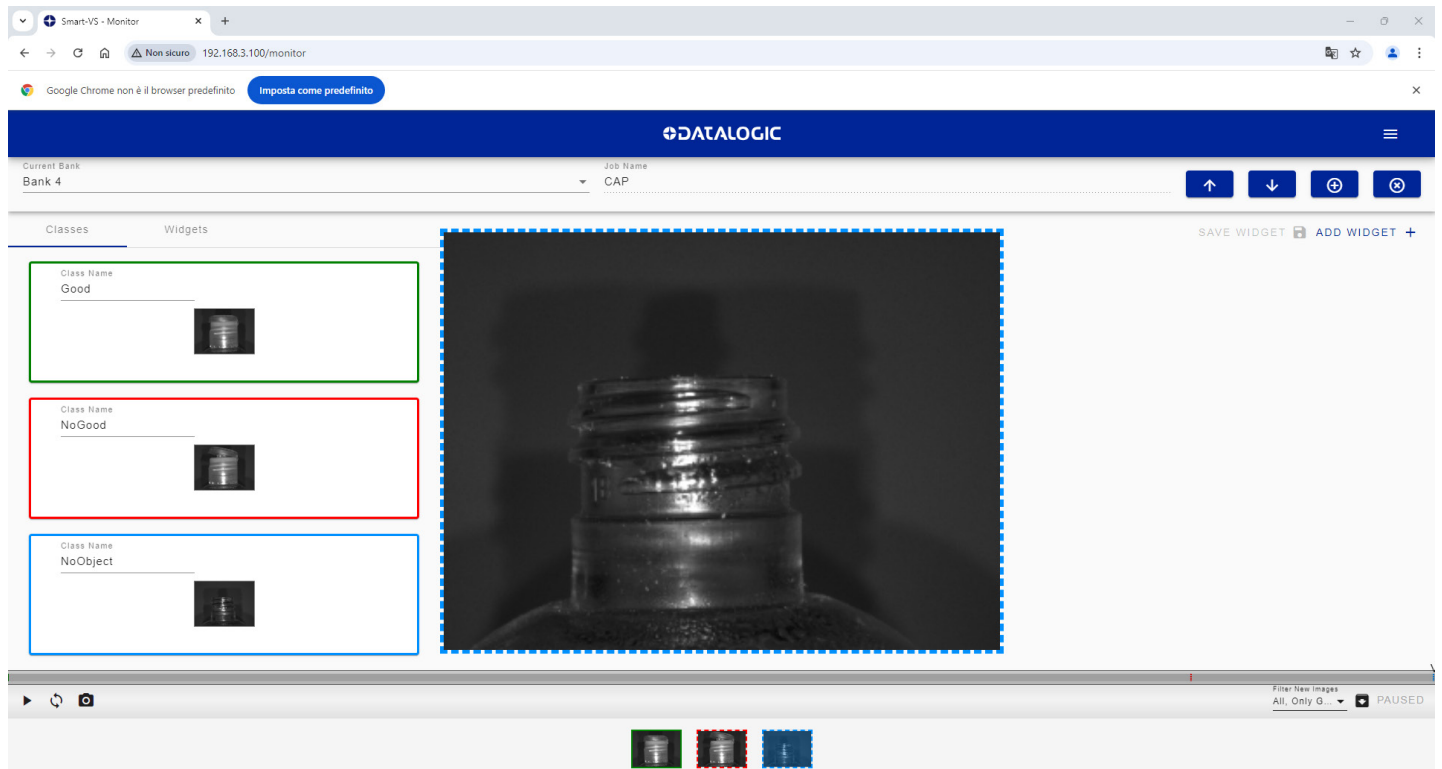

The Smart-VS is provided of a WEB Server User interface for an easy set-up and setting. This is a good option feature when it is needed to setup and change different production jobs depending on variable production format. The information are complete and shown in a clear layout.

CATEGORY	PART NUMBER	DESCRIPTION
<b>Cables</b>	95A900052	CAB-GD03 M12 17P 3M stripped wires
	95A900053	CAB-GD05 M12 17P 5M stripped wires
	93A050122	M12-IP67 GIGA Ethernet Cable X-Coded (1M)
	93A050123	M12-IP67 GIGA Ethernet Cable X-Coded (3M)
	93A050124	M12-IP67 GIGA Ethernet Cable X-Coded (5M)
	93A050128	Adapter Cable GIGA Ethernet X-Coded M12 to RJ45
	93A050129	Adapter Cable GIGA Ethernet X-Coded M12 to D-Coded
<b>Bracket</b>	93ACC0230	BK-22-000 Fixing Bracket M220 Body

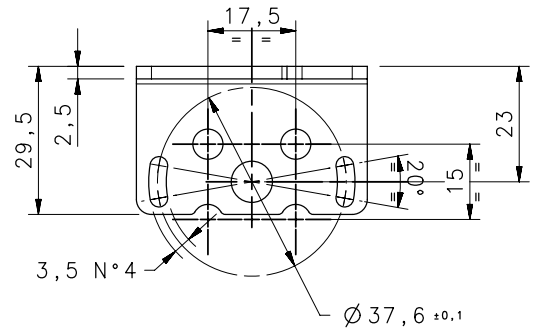
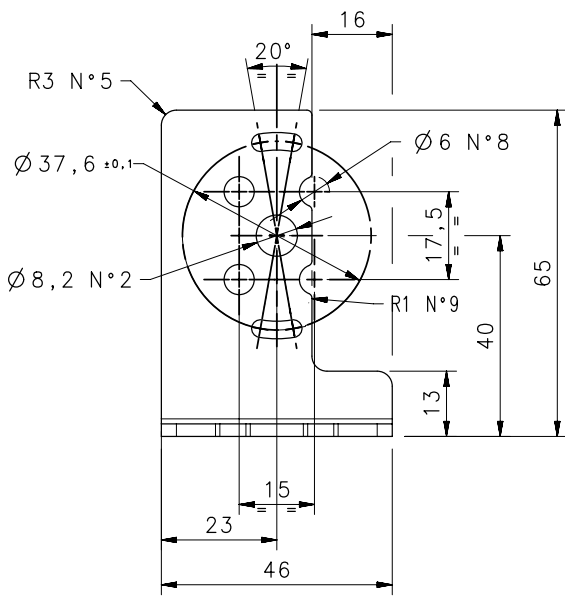

BK-22-000 Fixing Bracket